



Gibraltar 9600 Series Hardware

KAMAN
music corporation

Check out the entire line of Gibraltar
Hardware products at ...
www.GibraltarHardware.com

Replacement Part Numbers

- 1 - GP-0016 Upper Pull Rod
- 2 - SC-4420S Super Hi-Hat Clutch
- 3 - SC-HHCF Cup Felt
- 4 - SC-HHFW Flat Washer
- 5 - GP-0017 Upper Height Adjust Tube 1"
- 6a - GP-2005 Nylon Inner Sleeve 3/4"
- 6b - GP-2002 Nylon Inner Sleeve 1"
- 7 - GP-HML1 Hinged Memory Lock 1"
- 8 - GP-6030 Wing/ Black Bolt Set 6mm
- 9 - GP-6092 Lower ML Base Assembly
- 10 - SC-0009 8mm Wing Bolt
- 11 - SC-4208 Large Single Chain for Hi-Hat
- 11B - GP-6097 Direct Pull Rod (not shown)
- 12 - GP-5200 Hinged Pedal Board
- 13 - SC-2000 Pedal Hinge Assembly
- 14 - SC-PC09 Round Rubber Foot
- 15 - GP-5242 Rock Plate Screw Kit
- 16 - GP-6026 Quick Release Rock Plate-DP
- 17 - GP-6014 Ultra Adjust Stand Top
- 18 - GP-6015 Ultra Adjust Threaded T-Bolt
- 19 - GP-6016 Snare Stand Base
- 20 - GP-6012 Clydesdale Rubber Foot
- 21 - SC-13P2 Wing Nut 8mm
- 22 - SC-CFS/4 Small Cymbal Felt
- 23 - SC-19B Cymbal Sleeve 8mm
- 24 - GP-6084 Brake Tilter Top
- 25 - GP-6085 Brake Tilter Wing Nut/Bolt Set
- 26 - SC-LBRA-BT Brake Tilter Boom Arm
- 27 - GP-6068 Hex Bolt/Wing Nut Assm.
- 28 - GP-6093 3/4" Upper Height Adjust Tube
- 29 - GP-6078 3/4" Fitted memory Lock
- 30 - GP-6094 1" Middle Tube
- 31 - GP-2080 1" Fitted Memory Lock
- 32 - GP-6095 Lower Base Assembly
- 33 - GP-6096 3/4" Upper Adjust Tube
- 34 - SC-DSAB Dual Surface Beater
- 35 - GP-6000 Beater Holder
- 36 - GP-6002 Spring Rocker Hub
- 37 - GP-4007 Pedal Chain
- 38 - GP-5200 Complete Hinged Pedal board
- 39 - GP-5096 Spring Assembly
- 40 - GP-5103 Spring Tension Assembly
- 41 - GP-0020 Anchor Screw Assembly
- 42 - GP-5074 Hoop Clamp Assembly
- 43 - GRP2 - 3 Hole Rock Plate

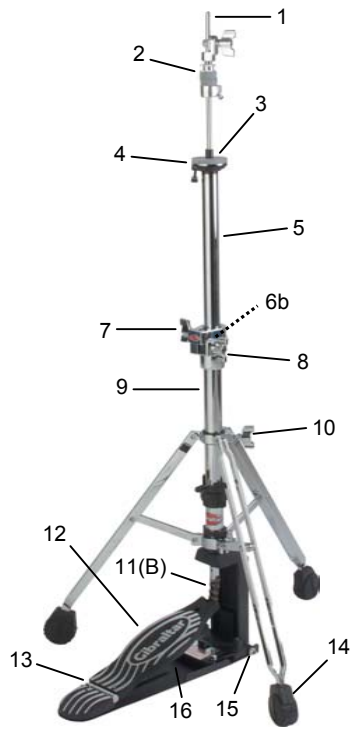

Hi-Hat Stand Setup Instructions

- A)** Remove cardboard and plastic cover from pedal board and slide pedal frame into the Quick Release Rock Plate.
- B)** Slide the Rock Plate frame stabilizing bracket into a forward position against the lower frame and tighten the wing nuts for solid positioning.
- C)** Unfold and adjust legs to be flush to the ground. This will stabilize the pedal board.
- D)** Screw the upper pull rod (GP-0016) into the threaded rod base stem.
- E)** Place the upper height adjust tube into the base and adjust to the desired position. Use the memory lock to retain this position.
- F)** Place the bottom hihat onto the hihat cup facing upwards. Tighten the clutch to allow at least a 1" space between the hihat cymbals.
- G)** Place the top hihat into the clutch and slide it onto the upper pull rod.
- H)** Use the Step Tension Adjustment lever on the base to change the spring tension.



Snare Stand Setup Instructions

- A)** Open the tripod base of the snare stand (GP-6016) and place it in an upright position.
- B)** Insert the upper snare basket tube (GP-6014) into the stand base.
- C)** Use the Fitted Memory Lock (GP-HML1) to secure the height.
- D)** Once the snare drum is placed in the basket, slightly tighten the basket to secure the drum. Be aware that over tightening the basket may choke the drum sound, limiting the response.

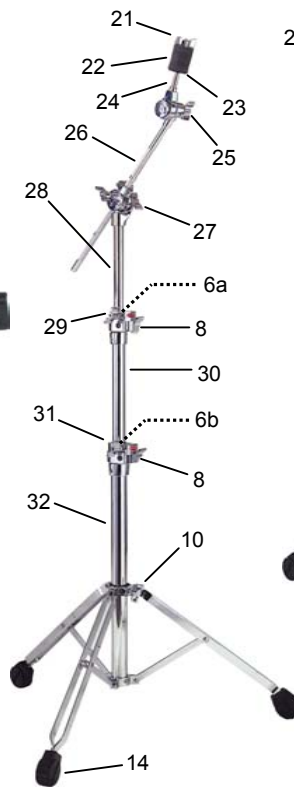

Cymbal Stand Setup Instructions

- A)** Open the tripod stand base (GP-6095) of the cymbal stand and place it in an upright position.
- B)** Insert the middle and upper cymbal tube into the stand base.
- C)** Insert the boom arm, 9609 only, into the upper tilter assembly.
- D)** Use the tilter on the upper height adjust tube and, or, the boom arm to position your cymbal to the desired angle.



Bass Drum Pedal Setup Instructions

- A)** Remove cardboard and plastic wrap from the pedal board.
- B)** Insert the beater (SC-DSAB) into the beater holder (GP-6000) and adjust it to your desired height.
- C)** Insert the pedal spring cam (GP-6002) onto the knurled hub that is on the axle.
- D)** To adjust the spring tension to your desired response, loosen both upper and lower finger nuts to increase or decrease the tension, then re-tighten the finger nuts.
- E)** Slide the pedal frame onto the bass drum hoop and tighten the hoop clamp (GP-5074) down to the bass drum hoop.
- F)** To avoid pedal slippage and bass drum movement, place the bass drum and pedal onto a carpeted surface.
- G)** Lubricate metal-to-metal contact points periodically to insure smooth operation. We suggest #SC-GLO Gibraltar Pedal Lubricant.

